



casagrande



Hydraulic crawler drill

Perforatrice idraulica

C6

Dati tecnici

Technical Specifications

C6



Caratteristiche Carro		Undercarriage	
Larghezza sottocarro	Overall width of undercarriage	7.4 ft	2250 mm
Larghezza pattini	Track shoes width	15.7 ft	400 mm
Lunghezza cingoli	Overall track length	9.8 in	2990 mm
Velocità di traslazione	Travel speed	0 ÷ 1 mph	0 ÷ 1,7 km/h
Pendenza max. superabile	Max. gradeability	37%	20°
Pressione specifica al suolo	Ground pressure	97 PSI	6,8 N/cm ²
Motore		Engine	
		DEUTZ	
Tipo	Type	TCD 2013 L04 2V (EPA/COM III)	
Potenza a 2300 giri	Rated power at 2300 r.p.m.	126,5 HP	93 kW
Capacità serbatoio gasolio	Fuel tank capacity	50 gal	190 l
Capacità serbatoio olio idraulico	Hydraulic oil tank capacity	159 gal	600 l
Mast		Mast	
Lunghezza mast	Mast lenght	19.7 ft	6000 mm
Corsa testa di rotazione	Stroke of rotary head	13 ft	4000 mm
Forza di estrazione	Extraction force	14,275 lbs	63,5 kN
Spinta sull'utensile	Crowd force	7,870 lbs	35 kN
Morse		Clamps	
		M2Z/M2SZ	
		M4/M4S	
Diametro	Diameter	40 ÷ 254 mm	60 ÷ 305 mm
		1.6 ÷ 10 in	2.4 ÷ 12 in
Forza di chiusura	Clamping force	145 kN	250 kN
		32,600 lbs	56,200 lbs
Testa di rotazione		Rotary head	
		T1200 6V	
Coppia max.	Max. torque	9,994 ft lb	13550 Nm
Giri max.	Max. speed	530 rpm	530 rpm
Ingombri e pesi		Dimensions and weights	
Lunghezza	Length	25.3 ft	7712 mm
Larghezza	Width	7.4	2250 mm
Altezza	Height	9 ft	2767 mm
Peso attrezzatura	Weight of rig	28,000 lb	12700 kg



C6

Dimensioni
Dimensions

Mast Standard
Standard Mast

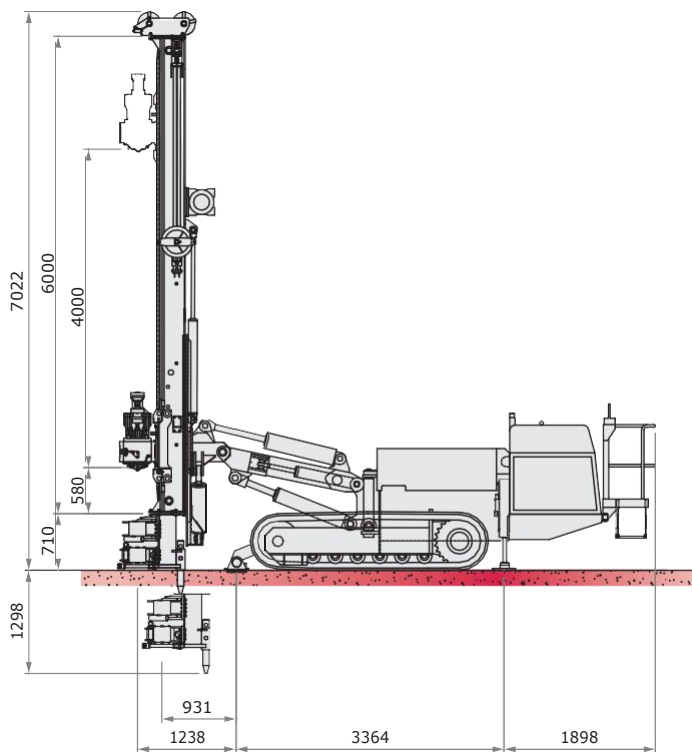

Mast lungo con motoriduttore
Long Mast with motorgear box

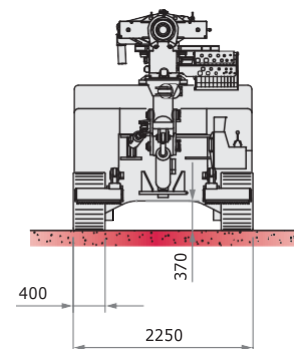
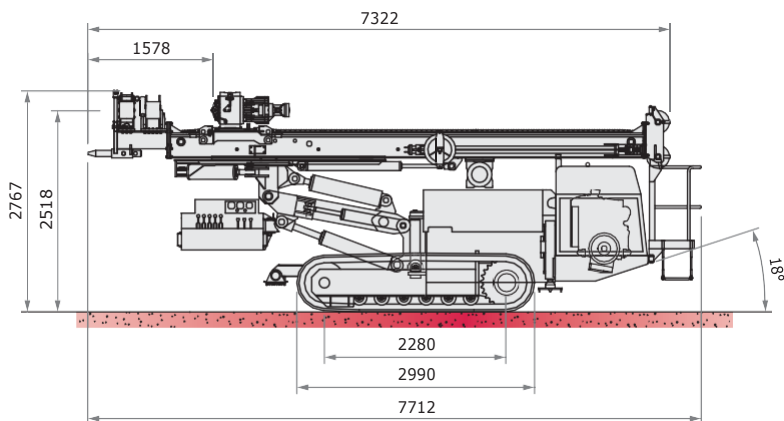
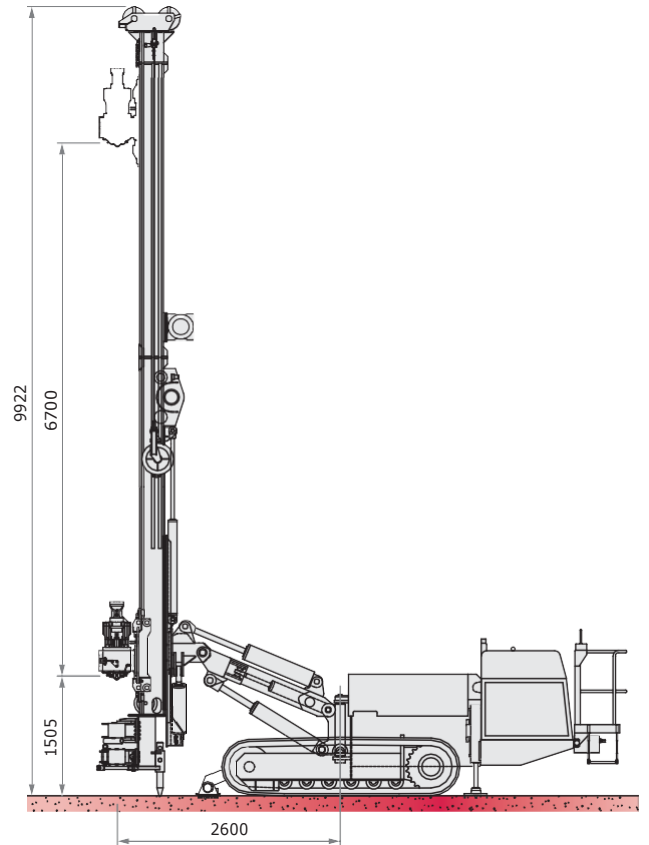

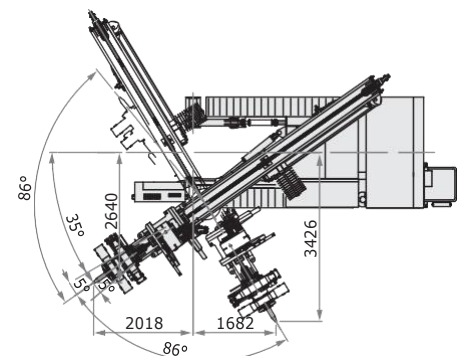
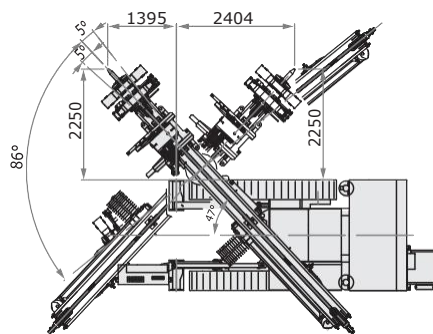
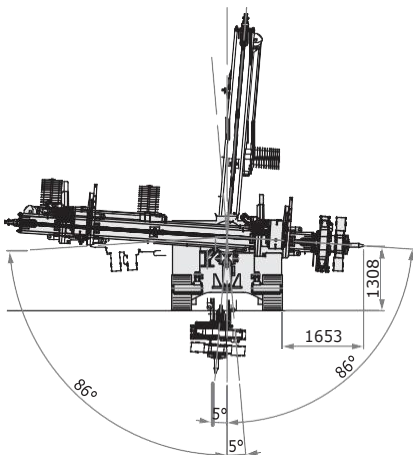
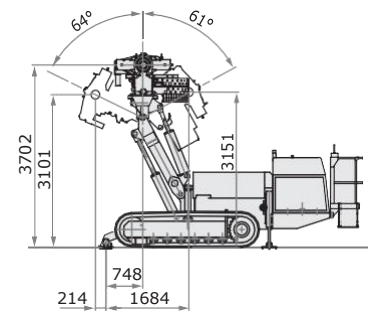
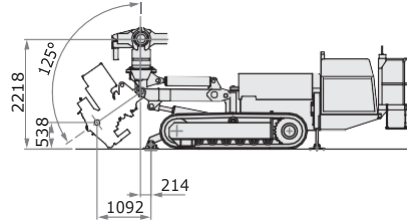
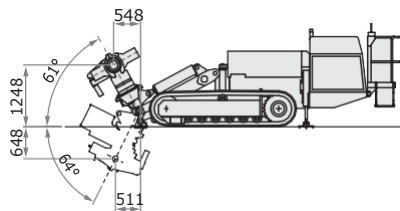
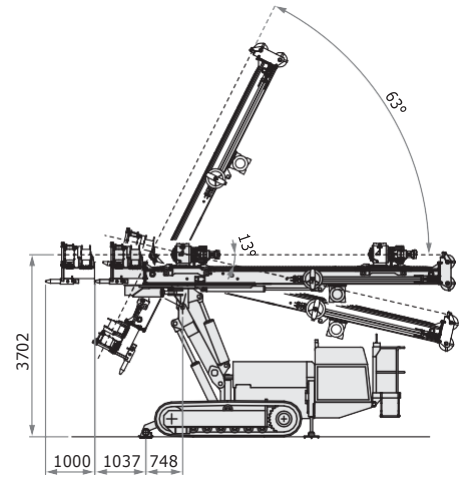
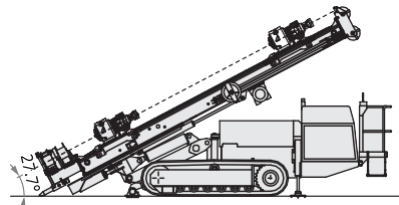
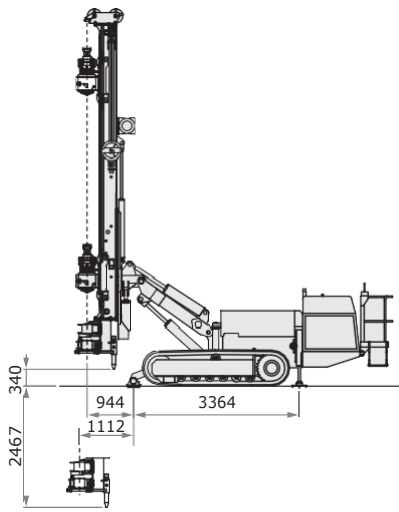



OPTIONALS

Argano tipo A2 - tiro max. - 20 kN / Winch type A2 - max. line pull - 4,496 lbs
 Martello esterno D21 - 1800 blows/min / External drifter type D21 - 1800 blows/min
 Doppia testa di rotazione / Double rotary head
 Spostamento laterale testa / Lateral movement of rotary head
 Caricatore a 2 aste - Ø max. 140 mm / Rod loader for 2 rods - 5.5 in
 Prolunga tralicciata - 2 x 5000 mm / Lattice mast extension - 2 x 16.4 f
 Pompa acqua - schiumogeni / Pumps for water - foam
 Oliatori / Oilers